

## Standard-Unterschraubmesser, gebohrt / *Two bevel profiles, drilled*

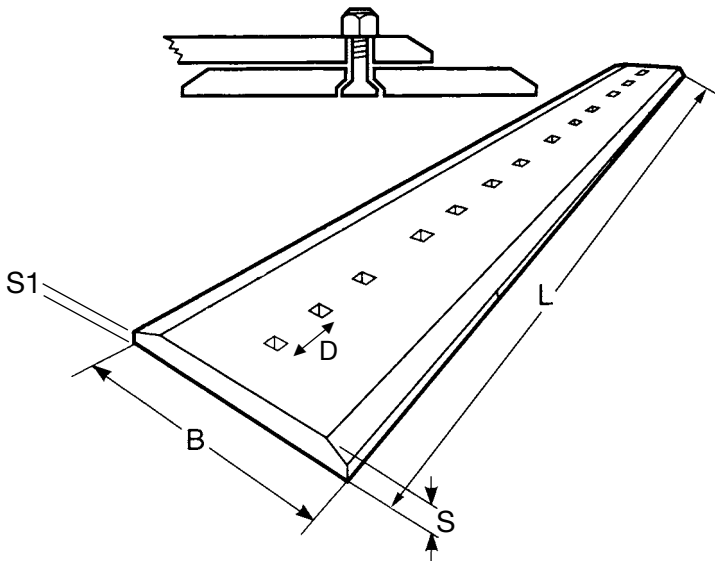

### Standard-Unterschraubmesser

- Aus warmgewalztem, hochverschleißfestem Borstahl, gehärtet auf ca. 500 HB
- Gebohrt mit 2 Fasen
- 6" Lochabstand

### Two bevel profiles

- Made of hot rolled Boron steel, hardened to approx. 500 HB
- Drilled and through-hardened
- 6" bolt hole pitch

Abmessungen <i>Dimensions</i>						Gewicht <i>Weight</i> KG	VeRotool-Bestell-Nr <i>VeRotool-No.</i>
B/mm	S	S1	Ø bolt (II)	D (II)	L/mm <i>ca./approx.</i>		Ca./approx 500 HB
152	16	5	5/8	6	6600	17,4	600.150 x 16 x 6 x 5/8
152	19	8	5/8	6		20,1	600.150 x 20 x 6 x 5/8
203	19	8	5/8	6		28,4	600.200 x 20 x 6 x 5/8
203	19	8	3/4	6		28,4	600.200 x 20 x 6 x 3/4
203	25	14	3/4	6		38,5	600.200 x 25 x 6 x 3/4
254	25	13	5/8	6		48,6	600.250 x 25 x 6 x 5/8
254	25	13	3/4	6		48,6	600.250 x 25 x 6 x 3/4
254	25	13	7/8	6		48,6	600.250 x 25 x 6 x 7/8
254	25	13	1	6		48,6	600.250 x 25 x 6 x 1
305	28,5	13	3/4	6		63,4	600.300 x 30 x 6 x 3/4
330	28,5	15	3/4	6		69,0	600.330 x 30 x 6 x 3/4
330	28,5	15	1	6		70,1	600.330 x 30 x 6 x 1
330	32	18	1 1/4	6		70,1	600.330 x 30 x 6 x 1 1/4
330	35	21	1	6		86,9	600.330 x 35 x 6 x 1
330	41	27	1	6		102,5	600.330 x 40 x 6 x 1
406	41	25	1	6		125,8	600.400 x 40 x 6 x 1
406	41	34	1 1/4	6		125,8	600.400 x 40 x 6 x 1 1/4

Dazu Einschweißmesser mit passendem Bohrbild verfügbar / *Base edges with suitable bolt hole pitch on request*