

Gradermesser / Grader blades and end bits

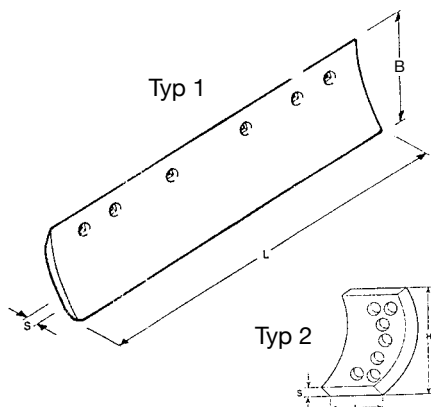

Gradermesser

- Aus gewalzten Profilen
- Naturhart und mit hohem Kohlenstoffanteil gegen vorzeitigen Verschleiß

Grader blades

- Made from rolled sections
- High Carbon steel to protect against wear

Die Form des Artikels kann von der Skizze abweichen /
 The shape of the component may differ from the sketch.

| Typ Type | Abmessungen (mm) Dimensions (mm) | | | | Ref.-Nr. Ref.-No. | Gewicht Weight KG | VeRotool-Bestell-Nr. VeRotool-No. |
|-------------|-------------------------------------|----|------|------------|----------------------|-------------------------|--------------------------------------|
| | B | S | L | Ø bolt (") | | | 25-30 HRc |
| 1 | 152 | 16 | 1828 | 3/4 | 9J3657 | 29,0 | 33.6x6x5/8-3/4 |
| 1 | 152 | 19 | 1524 | 5/8 | 3G7966 | 30,0 | 33.6x5x3/4 |
| 1 | 152 | 19 | 1828 | 5/8 | 5D9556 | 36,0 | 33.6x6x3/4 |
| 1 | 152 | 19 | 2133 | 5/8 | 5D9557 | 42,0 | 33.6x7x3/4 |
| 1 | 203 | 19 | 1524 | 5/8 | 9W6252 | 43,0 | 33.8x5x3/4 |
| 1 | 203 | 19 | 1828 | 5/8 | 5D9558 | 51,0 | 33.8x6x3/4 |
| 1 | 203 | 19 | 1828 | 5/8 | 7T1634 | 50,0 | 33.8x6x3/4-50HRc |
| 1 | 203 | 19 | 2133 | 5/8 | 7T1623 | 60,0 | 33.8x7x3/4-50HRc |
| 1 | 203 | 19 | 2438 | 5/8 | 7D1949 | 66,0 | 33.8x8x3/4-3/4 |
| 2 | 150 | 16 | 473 | 5 x 5/8 | 7D2052 | 7,5 | 33.7D2052 |
| 2 | 150 | 19 | 480 | 5 x 5/8 | 4130-339 | 9,3 | 33.4130339 |
| 2 | 152 | 19 | 374 | 4 x 5/8 | 4168-585 | 7,5 | 33.6x3/4 |

Gradermesser

- Aus gewalzten Profilen
- Vergütet für Einsätze mit sehr hohem Verschleiß

Grader blades

- Made from rolled sections
- Heat treated for high wear resistance

Abbildung s.o. / figure see above

| Typ Type | Abmessungen (mm) Dimensions (mm) | | | | Ref.-Nr. Ref.-No. | Gewicht Weight KG | VeRotool-Bestell-Nr. VeRotool-No. |
|-------------|-------------------------------------|----|------|------------|----------------------|-------------------------|--------------------------------------|
| | B | S | L | Ø bolt (") | | | 45-50 HRc |
| 1 | 152 | 19 | 1524 | 5/8 | 3G7966 | 30,0 | 33.6x5x3/4-50HRc |
| 1 | 152 | 19 | 1828 | 5/8 | 5D9556 | 36,0 | 33.6x6x3/4-50 HRc |
| 1 | 152 | 19 | 2133 | 5/8 | 5D9557 | 42,0 | 33.6x7x3/4-50 HRc |
| 1 | 203 | 19 | 1524 | 5/8 | 9W2340 | 43,0 | 33.8x5x3/4-50 HRc |
| 1 | 203 | 19 | 1828 | 5/8 | 7T1634 | 50,0 | 33.8x6x3/4-50 HRc |
| 1 | 203 | 19 | 2133 | 5/8 | 7T1623 | 60,0 | 33.8x7x3/4-50 HRc |

Weitere Abmessungen auf Anfrage / Further dimensions on request