

Schneidkantenstahl / Single bevelled cutting edges 500 HB

Schneidkantenstahl

- Durchgehärtet auf ca. 500 HB, gewalztes Profil

Cutting edge profiles

- Through hardened approx. 500 HB, rolled profile

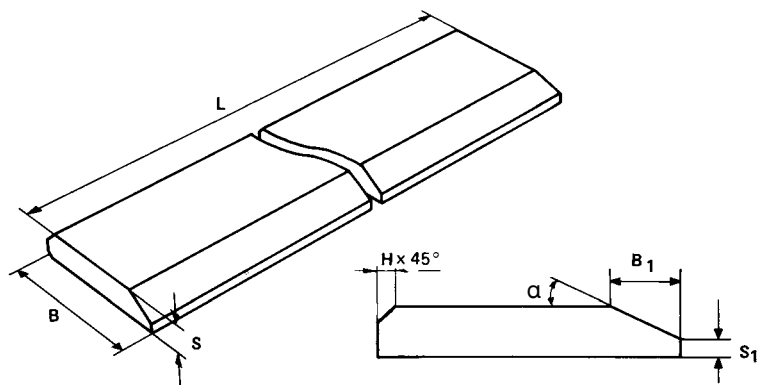

Abmessungen (mm) Dimensions (mm)							Gewicht Weight KG	VeRotool-Bestell-Nr. VeRotool-No.
B	S	S1	B1 ca./ approx.	α ca./ approx.	Schweißkante H Welding chamfer H	L max. ca./approx.		500 HB
80	12	5	19	20°	-	6600	7,1	30.08012.5
110	12	3	20	24°	R3	6150	9,6	30.11012.5
110	16	7	20	24°	R3	6150	13,1	30.11016.5
150	16	7	20	24°	5 x 45°	6150	18,0	30.15016.5
150	20	5	36	23°	5 x 45°	6150	21,3	30.15020.5
200	20	6	33	23°	8 x 45°	6150*	29,3	30.20020.5
200	25	11	33	23°	8 x 45°	6150	37,2	30.20025.5
200	30	10	44	25°	8 x 45°	6150	44,1	30.20030.5
250	25	6	46	23°	10 x 45°	6150	45,3	30.25025.5
250	30	11	46	23°	10 x 45°	6150*	55,0	30.25030.5
270	30	10	44	25°	8 x 45°	6150	60,9	30.27030.5
300	30	8	52	23°	10 x 45°	6150*	66,0	30.30030.5
300	35	13	52	23°	10 x 45°	6150*	77,7	30.30035.5
300	40	18	52	23°	10 x 45°	6150*	89,4	30.30040.5
300	45	18	18	23°	10 x 45°	3700	98,9	30.30045.5
300	50	28	52	23°	10 x 45°	6150	112,9	30.30050.5
400	30	8	34	23°	10 x 45°	3700	89,4	30.40030.5
400	40	15	56	24°	12 x 45°	6150*	118,4	30.40040.5
400	45	20	56	24°	12 x 45°	6150	132,8	30.40045.5
400	50	25	56	24°	12 x 45°	6150	148,5	30.40050.5
400	60	35	56	24°	12 x 45°	7200	185,0	30.40060.5

* Auch in Sonderlängen von ca. 7500 mm lieferbar / also available in a length of 7500 mm