

Schneidkantenstahl, vorgebohrt / single bevelled cutting edges, drilled

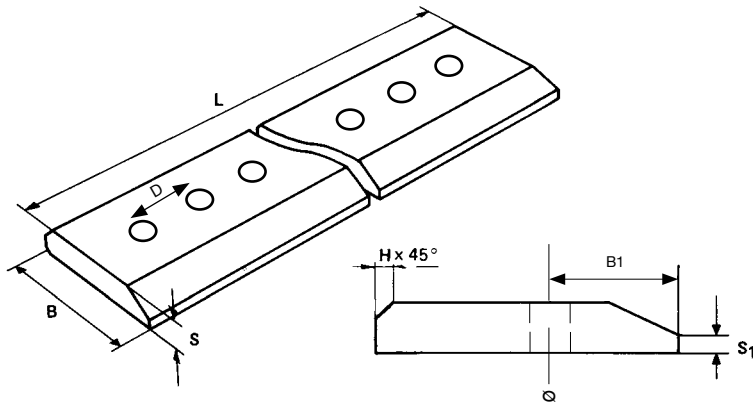

Schneidkantenstahl, vorgebohrt

- Durchgehärtet auf ca. 500 HB, gewalztes Profil

Cutting edge profiles, drilled

- Through hardened approx. 500 HB, rolled profile

Abmessungen (mm) Dimensions (mm)						Gewicht Weight KG	VeRotool-Bestell-Nr. VeRotool-No.
B	S	B1 ca./ approx.	Ø	D (")	L max. ca./approx.		ca./approx. 500 HB
200	20	50	22	152,40 (6")	6100	28	30.200x20x6x22-50
200	20	70	22	152,40 (6")	6100	28	30.200x20x6x22-70
250	25	65	22	152,40 (6")	6100	44	30.250x25x6x22-65
250	25	90	22	152,40 (6")	6100	44	30.250x25x6x22-90
300	30	70	27	152,40 (6")	6100	64	30.300x30x6x27-70
300	30	105	27	152,40 (6")	6100	64	30.300x30x6x27-105