

Standard-Unterschraubmesser, ungebohrt Double bevelled profiles, undrilled

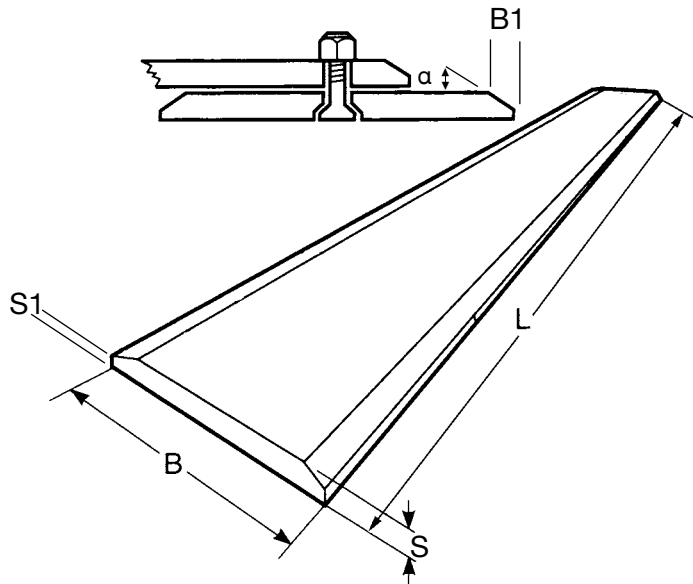

Standard-Unterschraubmesser

- Aus warmgewalztem, hochverschleißfestem Borstahl, gehärtet auf ca. 500 HB
- Ungebohrt, mit 2 Fasen

Double bevelled profiles

- Made of hot rolled Boron steel, hardened approx. 500 HB
- Not drilled

Abmessungen (mm) Dimensions (mm)						Gewicht Weight KG	VeRotool-Bestell-Nr. VeRotool-No.
B	S	S1	B1 ca./approx.	α ca./approx.	L ca./approx.		500 HB
152	16	5	24	25°	6600	17,4	600.150x16x6.U
152	19	8	24	25°	6600	20,1	600.150x20x6.U
203	25	8	24	25°	6600	28,4	600.200x25x6.U
203	19	14	24	25°	6600	38,5	600.200x25x6.U
254	19	7	26	25°	6600	35,7	600.250x20x6.U
254	25	13	26	25°	6600	48,6	600.250x25x6.U
254	32	20	26	25°	6600	61,4	600.250x30x6.U
280	25	7	44	23°	6600	48,8	600.280x25x6.U
304	25	10	38	23°	6600	56,0	600.300x25x6.U
305	29	13	38	23°	6600	63,4	600.300x30x6.U
330	29	15	34	23°	6600	70,1	600.330x30x6.U
330	35	21	34	23°	6600	86,9	600.330x35x6.U
330	41	27	34	23°	6600	102,5	600.330x40x6.U
360	30	8	53	23°	6600	75,6	600.360x30x6.U
360	35	13	53	23°	6600	89,7	600.360x35x6.U
360	40	18	53	23°	6600	103,9	600.360x40x6.U
406	30	13	39	23°	6600	86,0	600.400x30x6.U
406	41	25	39	23°	6600	125,8	600.400x40x6.U
406	50	34	39	23°	6600	154,5	600.400x50x6.U